



VACUUM PLUMBING SYSTEMS

Grocery Stores



## A Versatile Engineered Plumbing and Waste Solution



Hotels



Detention Centers



Educational Buildings



Office Buildings



Healthcare Facilities

## Table of Contents

Who We Are / What We Do / Service .....	1
The Company.....	2
The Versatile Plumbing Solutions to Renovation and New Construction Challenges.....	3
Renovation Construction/Historical Buildings.....	3
Construction Benefits of Vacuum Plumbing .....	4
Cost Savings Benefits of Vacuum Plumbing.....	5
Service and Maintenance Benefits of Vacuum Plumbing .....	6
Health, Safety and Welfare Benefits of Vacuum Plumbing.....	7
LEED Credits .....	7
Why Vacuum Plumbing is the Environmental Choice .....	8
What is a Vacuum Plumbing System? .....	8
When to Choose an Engineered Vacuum Plumbing System .....	9
How it Works .....	10-13
Products and Services .....	14-27
AcornVac Services - We Can Assist You through the Entire Construction Process .....	14-15
Championship Product Series .....	16-17
System 100-Series AV-20S-1.2-LR-BV .....	18
System 150-Series AV-30S-2.2-LR-ST.....	19
System 200-Series AV-30S-2.2-LR .....	20
System 300-Series AV-30S-2.3-LR .....	21
System 500-Series AV-60S-2.5-LR-STK .....	22
System 1000-Series AV-60S-3.5-LR-3T-STK .....	23
Pneumatic Manual Control Valve System .....	24
Master-Trol™ Electronic Control Valve System.....	25
Zone Electronic Control Valve System .....	26
Complementary Products – Plumbing, Drainage, and Toilets .....	27
Benefit for Institutional Construction - Prisons • Jails • Correctional Centers .....	28
Benefit for Food Service Industry - Supermarkets • Convenience Stores • Delicatessens .....	29
Benefit for Health Care Facilities – Laboratories • Clinics • Medical Centers .....	30
Grease Waste Transport System.....	31
Frequently Asked Questions .....	32-33



## Who We Are

AcornVac, Inc. designs, engineers, manufactures and markets environmentally friendly plumbing and waste collection, conveyance and disposal systems.

AcornVac has the expertise and knowledge to deliver a state-of-the-art, reliable, cost effective and versatile plumbing system that is engineered to fit most any building type for renovation and new construction projects.

The AcornVac solution minimizes the use of fresh water for toilet flushes. This in turn contributes to a smaller water and sewage footprint for any building. At the same time, AcornVac's versatile plumbing system delivers the ultimate freedom of piping layout and works with drainage from condensate, grey water and sanitary sources.

## What We Do

Our skilled personnel, professional design, and high quality technical solutions can help solve difficult wastewater engineering problems. Our versatile plumbing system employs vacuum to resolve many of the installation concerns and costs of other plumbing systems. We take into account our customer's needs in the design process to deliver a plumbing system that works with minimal site disruption, requires less space, is cost effective for the application and addresses environmental concerns.

We are the people to call when there is a difficult project or design situation. We have the broad experience in not only design but also the hands-on operation, maintenance and troubleshooting of systems. We will be there from the beginning to the end; from design to operation. Our technical support staff is available to assist with the vacuum plumbing system operation any time that it is needed.



## Service

Our decades of experience have resulted in the creation of the most advanced products and designs in the market today. The AcornVac R&D team ensures that we stay on the cutting edge of vacuum technology with both products and design. We offer turn-key and custom systems. Our expertise is in designing and supplying the right plumbing system for the application at hand.

With installations domestically and internationally, AcornVac's design engineers, installers and project managers have been involved in a large variety of projects, each with different types of environmental and engineering challenges.

All of our customers are assisted with a professional training program with the purchase and installation of an AcornVac Plumbing System, as well as, periodic inspections during installation, commissioning and operational training.

In addition to the above services, we offer continuing education seminars and presentations good for LUs and CEUs at no cost.



## The Company

AcornVac, Inc. is a subsidiary of Acorn Engineering's Family of Companies, City of Industry, California. AcornVac continues Acorn Engineering's 60 year tradition of setting industry standards with innovative products and systems. Acorn Engineering's Family of Companies manufactures a wide variety of products including:

- Stainless Steel Engineered Plumbing Fixtures and Accessories
- Drinking Fountains, Water Coolers and Chillers
- Custom Injection Molding
- Residential Luxury Bath Fixtures
- Healthcare and Therapy Products
- Access Doors and Roof Flashings
- Outdoor Drinking Fountains; Hydrants; Pre-Engineered Buildings for Parks and Recreation Applications; Bicycle Security
- Emergency Eyewashes, Combination Showers, and Drench Showers
- Tankless/Instantaneous Water Heaters
- Fire Protection Equipment
- Fire Fighting Monitors & Nozzles
- Plumbing and Drainage Products

AcornVac's Engineering, Research & Development and Manufacturing complex is located in Chino, California.

Contact us with your design and product questions. We can help you with your versatile plumbing systems (VPS).

### AcornVac, Inc.

#### Vacuum Plumbing Systems

13818 Oaks Avenue, Chino, CA 91710

Tel. 800-591-9920 • Tel. 909-902-1141

Fax: 909-902-5041

Email: [info@acornvac.com](mailto:info@acornvac.com)

[www.acornvac.com](http://www.acornvac.com)



**ACORN ENGINEERING COMPANY**

FAMILY OF COMPANIES

### Certifications and Listings



**Building Material Evaluation Commission**

Toronto, Ontario, Canada

Authorization Number:

BMEC-06-09-329

Application: BMEC A2006-11

**Note:** For a complete list of State and Local Approval, please contact AcornVac in Chino, CA.



*New Construction and Renovation Solutions*

## The Versatile Plumbing Solutions for Renovation and New Construction Challenges

The versatility of the AcornVac System makes it the first choice in renovation and new construction projects. With our system there are installation cost savings, material cost savings, water use savings and sewage discharge savings. Some of the major applications include:

Institutional Construction	Commercial Construction
Healthcare Facilities	Grocery Stores
Educational Buildings	Hotels
Detention Centers	Office Buildings

Because the vacuum system waste piping can be routed vertically or horizontally, we can place your plumbing waste system anywhere you want it!

The versatility and cost savings of a vacuum system is of particular value in tenant construction – notably malls, airports and medical office buildings.



## Renovation Construction/Historical Buildings

The AcornVac System can be of tremendous benefit in the renovation of historical buildings in which both mechanical design and preservation of the existing structure must be taken into consideration.

# Construction Benefits of Vacuum Plumbing

• **Renovation and Historical Projects** – Accommodates restrictive site and structural concerns, no trenching or cutting of slab. The piping system provides flexibility in plumbing fixture layout and building design.

• **Remodels** – Installation is quick and easy. It can be performed after-hours, eliminating customer inconvenience and liability issues. Since the plumbing is done within the envelope of the building there is no washed out concrete slab or rain delays. There is no cutting into the existing electrical, refrigeration or sewer lines.



*Floor Free of Patches*



*Eliminates Main Line Back-ups*



*Over-head Piping*

• **Open Architectural Design** – Enhances space utilization as it requires less space to install. The piping system is installed over-head with other mechanical or electrical systems. It eliminates the need to provide vent and waste stacks, thus reducing material and labor costs.

• **High Water Table** – Since waste is pushed by air pressure, shallow but long piping runs are possible. This eliminates or minimizes the need for dewatering and trench stabilization which may be required in areas with high water tables or unstable soil conditions.

• **Fixture Placement** – In an existing building plumbing fixtures and refrigeration systems can be relocated or added to any part of the building. The space can be adapted to new occupant or design needs. Turn any space into valuable space with a versatile plumbing system!

• **Versatile** – The piping system uses a smaller diameter pipe than gravity waste systems, yet it can accommodate a range of waste types and flow rates. With a vacuum system, changing the piping connection to go in a new direction is simple and allows for last minute design changes.



*Versatile Design*

• **Facility Use** – Allows existing buildings to be developed when traditional systems are cost prohibitive, due to:

- Structural limitations such as a post tension slab;
- Restrictive site issues like bedrock, inappropriate inverts, or a historical building categorization; or
- Embedded contaminant in the floor or slab similar to asbestos or other pollutants.

“AcornVac is a powerful money saver. For starters, we cut the Authority’s waste cost by \$200,000 a year. We saved \$400,000 up front in domestic water connect fees because AcornVac’s smaller piping network simplifies everything, and we drastically reduced how the inmates control the jail by eliminating clogged pipes.”

John Chaney  
AECOM HSMM Project Manager  
Western Virginia Regional Jail  
Salem, Virginia

## Cost Savings Benefits of Vacuum Plumbing

### • Construction Costs

– Eliminates or significantly reduces potential floor cutting and saves weeks in the overall construction cycle.



### • Post Tension Slab or Structural Slab Renovation

Eliminates the costly expense of having to x-ray the slab to find specific locations that are free of cables where a hole or trench could be cored for piping or waste pipe connection.

• **Water Savings** – Reduces potable water consumption for toilets by as much as 68% and reduces sewage waste discharge with a ½ gallon toilet flush.

• **Installation Materials and Labor** – Labor and material costs are reduced since the installation is above ground and smaller diameter water and waste piping are used. The costs associated with vent stack piping and expensive roof penetrations are also eliminated. The above-ground installation saves construction or remodel time and labor. On remodel work, the savings can be substantial depending on the size of the existing facility and the length and depth of trenching required for gravity waste pipe tie-in. Typical savings are 30% and in some cases much higher.

### • Other Cost Saving Benefits:

- Eliminates problems with miss-location of floor drain stub-ups, floor sinks and cleanouts.
- Minimizes cost impact and work required for engineering or design changes.
- Can significantly reduce sewage impact fees.
- Minimizes customer inconvenience and increases safety for staff and customers when used in commercial retail project renovations.
- Minimizes any potential plumbing renovation impact on lower level tenants in multi-story buildings.
- Vacuum drainage equipment can be capitalized, depreciated and taken with the owner if the business is relocated.

**Did You Know:** In a recent comparison for an average size county correctional facility, the cost impact of the vacuum system compared to gravity was approximately \$0.90 per square foot. When projected water savings were taken into account, the payback on the additional cost was less than five years.

### PROJECT EXAMPLE:

Mental Health Facility/Treatment Center, Salinas Valley State Prison

**LOCATION:** Soledad, CA

**COMPLETED:** July, 2009

### THE PROJECT TEAM:

- CDCR, Program Manager Kitchell CEM, Nacht & Lewis Architects, Capital Engineering, CB Engineering, Roebbelen Contracting Inc., and Green Building Services

### PROJECT DESCRIPTION:

The Salinas Valley State Prison is a 64-bed, 36,400 sq-ft mental health housing & treatment facility in Soledad, CA. The facility houses male inmates requiring inpatient mental health care at level IV security (the most violent). The project's aim is to achieve the first LEED certification for the State's prison system, ahead of the 2011 mandate.

### OBJECTIVES ACHIEVED:

#### Minimize water consumption and waste water treatment

A single inmate may flush his or her toilet more than an average household flushes in an entire day. A correctional facility operating at full occupancy uses a lot of water and it generates a lot of waste. AcornVac, in combination with other conservation efforts throughout the Salinas facility, contributes to a reduction in potable water use by 56 percent, as reported by the California Department of Corrections "and lowered sewage conveyance by nearly 70 percent;" far exceeding the Governor's Executive Order #S-20-04 and the LEED requirements.

#### Achieve Silver LEED certification status

The water savings from the AcornVac System, along with other attributes, contributed to a Silver LEED certification.

#### Boost security and minimize contraband

A toilet in a prison cell is used and abused in multiple ways; it can be used to dispose of trash, to hide contraband or to create distractions. With a vacuum plumbing system, the direct connection of multiple toilets into the same waste stack is eliminated, thereby preventing inmates from passing contraband between cells. Vacuum toilets eliminate cell-to-cell communication that inmates often use to create "planned plumbing chaos" by organizing large "group flushes" that are typical for gravity drainage systems.

#### Reduce Maintenance cost and effort

The AcornVac system in the Salinas Facility proved to be low maintenance, due in large part to its design. The system efficiently isolates every cell from the waste piping network by means of a normally closed valve separating the toilet in the cell from the rest of the toilets in the facility. Leaks and mainline clogs are virtually eliminated. The facility personnel report fewer maintenance calls. "There have hardly been any problems raised to our level of attention. We have no mainline blockages to report, and I haven't had to order any replacement parts."



*Flexibility to Move and Add Cases*

**Did You Know:** Depending on the depth of the sanitary sewer and the distance to a point of connection with existing sewer service, the cost of gravity waste pipe trenching can be expensive – in some instances over \$225 per linear foot. After less than 100 linear feet, AcornVac provides a cost saving solution!

*“We have hardly had any costs in maintenance. If something plugs up, it’s right there at the fixture, making it easy to isolate and fix. The vacuum system is better because everything must pass a valve, and once it does, it can’t be retrieved at the fixture.”*

*Dean Barchacky,  
Plant Manager, SVSP,  
Soledad, California*

## Service and Maintenance Benefits of Vacuum Plumbing

- **Reliable** – With hundreds of installations, small and large, worldwide, our systems have a proven track record of providing reliable and efficient performance.
- **Low Maintenance** – The vacuum interface components have been tested to well over one million cycles without failure. These components have no regular preventive maintenance requirement.
- **Plumbing Issues** – The operational dynamics of a vacuum system results in fewer main-line blockages, reducing maintenance cost and disruptions.



# Health, Safety and Welfare Benefits of Vacuum Plumbing

- **Indoor Air Quality** – Since there is no waste line trenching required, issues associated with concrete dust or asbestos abatement are eliminated and a healthier, safer environment can be maintained on renovation projects.

- **Maintain the Existing Slab** – No open trenches during the installation of the system eliminates construction safety issues.



- **Environmental** – A vacuum toilet uses only ½-gallon of water per flush. This provides significant savings in the water supply and sewage disposal costs. These features may contribute to LEED or green construction credits.

- **Safety** – Designed to provide complete redundancy on all primary Vac Center components. This includes dual collection tanks and multiple pumps.

- **OSHA Compliance** – Reduces compliance issues as there are no open trenches and the project can be open to the public.



*“The AcornVac System provided a healthy store environment for employees and guest during the construction process.*

*The system eliminates the saw cutting of the concrete throughout the store floor which would have produced a great deal of dust and residue - no matter how carefully you tarp off the area.*

*With the AcornVac System, we reduced the amount of construction waste, tile, concrete, carpeting, etc. while being environmentally friendly.”*

Gausman & Moor:  
Commercial Retail Remodel  
Santa Maria, CA

- **Health Hazards** – Creates a cleaner environment and reduces the health hazards associated with gravity drainage. Since the piping system is maintained under a continuous vacuum, waste water and debris is drawn into the system, not out, eliminating any issue or concern with waste piping leaks.

- **Health Authorities** – The system reduces any health risks associated with sewage waste line back-up at the fixture. Because toilets flush by drawing air into the toilet bowl, there is no splash during the flush cycle.

## LEED Credits Associated with an AcornVac Vacuum Plumbing System:

- **Water Use Reduction** – Increase water efficiency within buildings to reduce the burden on municipal water supply and wastewater systems. Employ strategies that in aggregate use less water than the water-use baseline calculated for the building. Use high-efficiency fixtures water closets and urinals.

- **Innovative Wastewater Technology** – Reduce generation of wastewater. Reduce potable water use for building sewage conveyance by 50% through the use of water-conserving fixtures such as water closets and urinals.

- **Building Reuse** – Extend the lifecycle of existing building stock, conserve resources, retain cultural resources, reduce waste and reduce environmental

impacts of new buildings as they relate to materials, manufacturing and transport. Consider reuse of existing, previously occupied buildings, including structure, envelope and elements. Upgrade components that would improve energy and water efficiency.

- **Innovation in Design** – To be awarded points for exceptional performance above the requirements set by the LEED Green Building Rating System. Apply strategies or measures that demonstrate a comprehensive approach and quantifiable environment and/or health benefits.

### LEED address the complete lifecycle of buildings

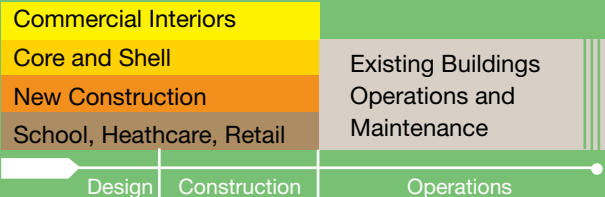

## Why Vacuum Plumbing is the Environmental Choice

A typical vacuum system can reduce potable water consumption for toilets by 68 percent with a highly efficient vacuum flush toilet requiring only a half gallon per flush. Of the many benefits vacuum plumbing offers, the water and waste treatment savings are one of the most important features of this technology. The water savings can be thousands of dollars and millions of gallons per year for larger applications.

**Did you know:** A 500 person commercial office building that is serviced by a single vacuum center and 1/2 gallon per flush vacuum toilets will save over 265,000 gallons per year, compared to conventional low flush toilets.

*“AcornVac in combination with other conservation efforts throughout the new facility contributes to a reduction in potable water use by a remarkable 56% and lowered sewage conveyance by nearly 70% through a state of the art vacuum plumbing system.”*

*California Department of Corrections on the AcornVac System installed at Salinas Valley State Prison Medical Treatment Center*



*Project Can Be Completed in a Confined Space with Little Disruption to Facility*

## What is a Vacuum Plumbing System?

Vacuum plumbing systems are simple and viable alternatives to underground piping that uses the combined energies of vacuum pressure and gravity for the collection, conveyance and disposal of waste through a piping network that can be routed above ground. Vacuum drainage operates on the principal of having a majority of the plumbing system under a continuous vacuum. Hundreds of vacuum drainage systems are in

operation around the world and are accepted by most code authorities. Vacuum systems are a viable drainage solution as noted in the latest edition of the IPC and UPC Codes. In addition, many local and state plumbing codes have also accepted vacuum plumbing as an approved alternative for a variety of waste types including condensate, grey water, sanitary waste and grease waste.

## When to Choose an Engineered Vacuum Plumbing System

While a vacuum plumbing system can be used on virtually any project, certain design and construction conditions may make it the most cost effective solution available. Here are some examples:

Conditions	Select Vacuum	Select Conventional
Proven technology	•	•
Conventional and low volume flush toilets	•	•
No space restrictions, site issues, water saving requirements or cost concerns		•
Limited amount of cutting, trenching and digging to tie into existing sanitary sewer		•
Renovation construction/ reuse of existing space in which there is limited existing points of connection to sanitary sewer and a moderate amount of waste line trenching is required	•	
Open architecture – with limited existing or available mechanical space – vacuum reduces space needed for waste piping	•	
Post tension or structural slab – vacuum eliminates cost of x-ray and trenching	•	
Restrictive site issues, bedrock, unstable soil, high water table, inappropriate inverts – vacuum waste piping is routed overhead	•	
Imbedded contaminates in the floor or slab, such as asbestos or other pollutes – no need to disrupt existing slab – vacuum waste piping is routed overhead	•	
Lack of as built documentation for structures in which there is concern for buried services	•	
Available water and sewage service – vacuum flush toilets require 68% less water per flush and can offer opportunity for reduced sewage impact fees	•	
Reduced maintenance – vacuum waste systems reduce main line blockages	•	
Concern for soil contamination – vacuum waste systems eliminate waste exfiltration	•	

# Components of a Typical Vacuum System

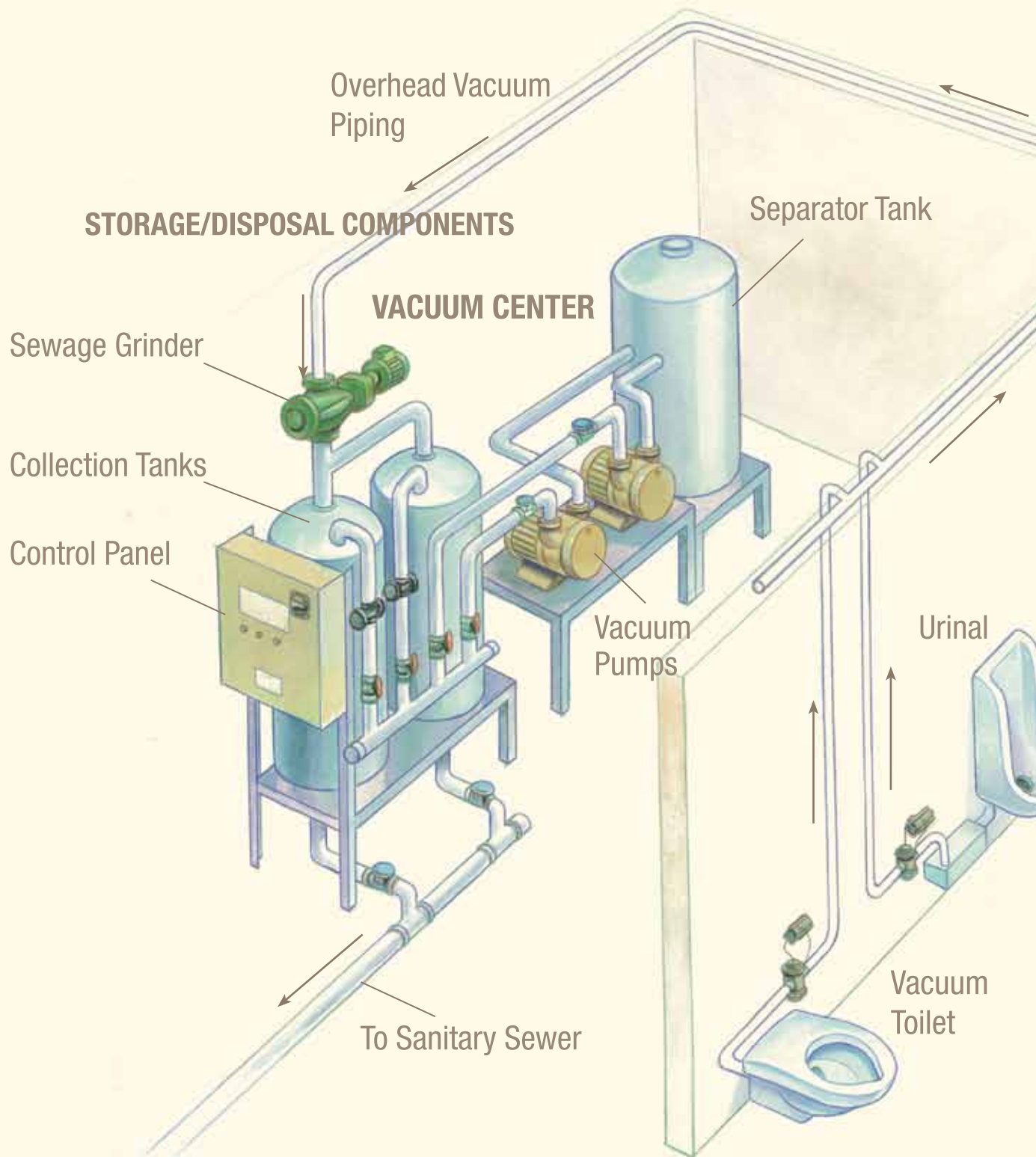

# How it Works: An Introduction to Vacuum Sewage and Plumbing Systems

A Vacuum Drainage System consists of three basic components:

**1. Collection Points** – Typical sanitary and gray water collection points include toilets, sinks, showers, urinals, and drinking fountains. Typical condensate collection points consist of refrigeration coils, service coolers and freezers as well as frozen and refrigerated food display cases.

**2. A Conveyance System** – The vacuum drainage piping network can be routed where most convenient including overhead or through voids in ceiling spaces. This allows for transport of waste from its point of origin to the vacuum generating station.

**3. Storage/Disposal Components** – A vacuum generating station [Vac Center] includes the vacuum pumps that create a vacuum in the piping and storage tanks that collect and discharge the waste into the sewer system. The vacuum pumps run only on demand and redundancy is provided. The Vac Center may also include sewage discharge pumps that pump waste from the storage tanks into the sewer.

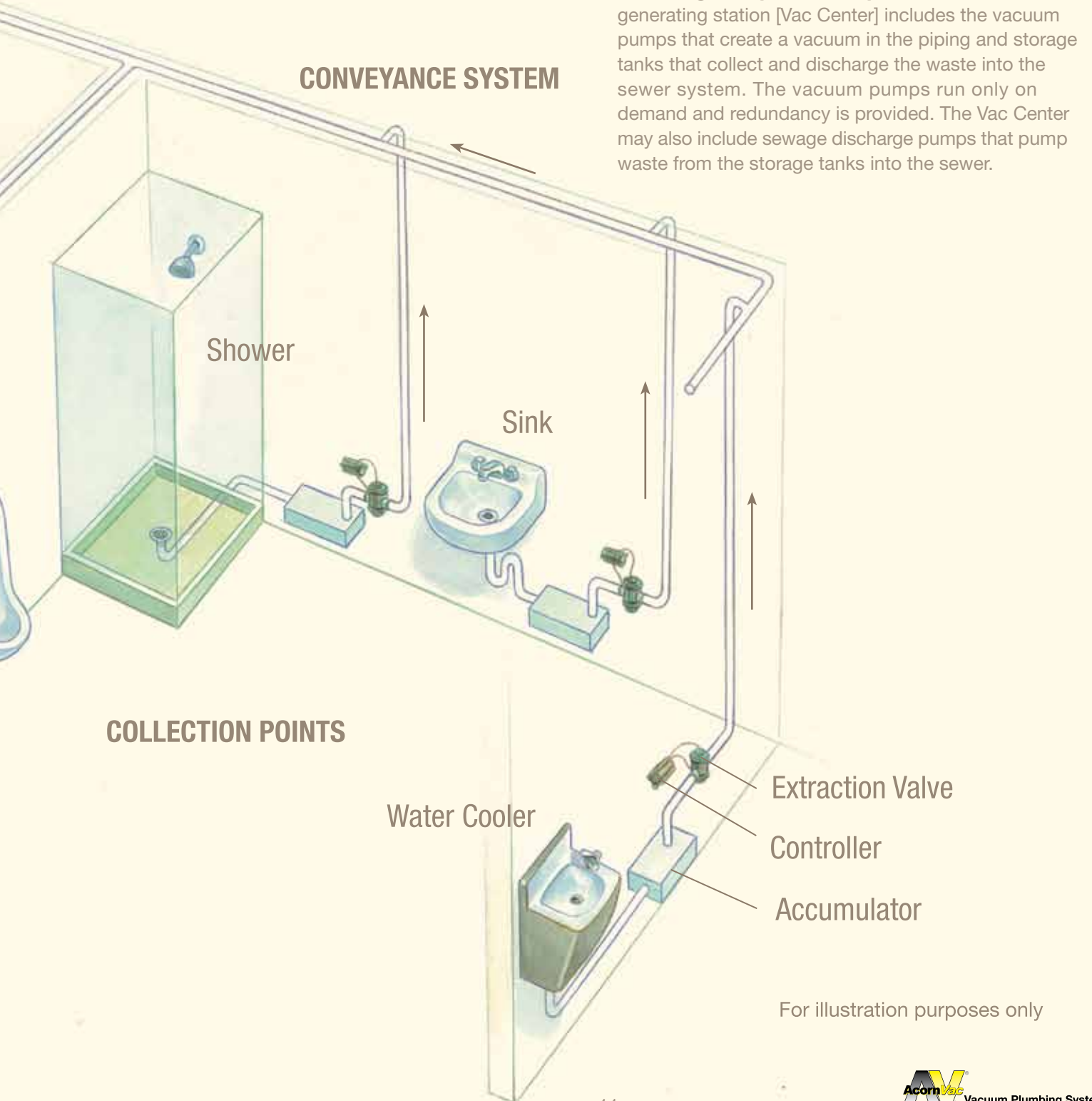

## Toilet Flush and Drainage

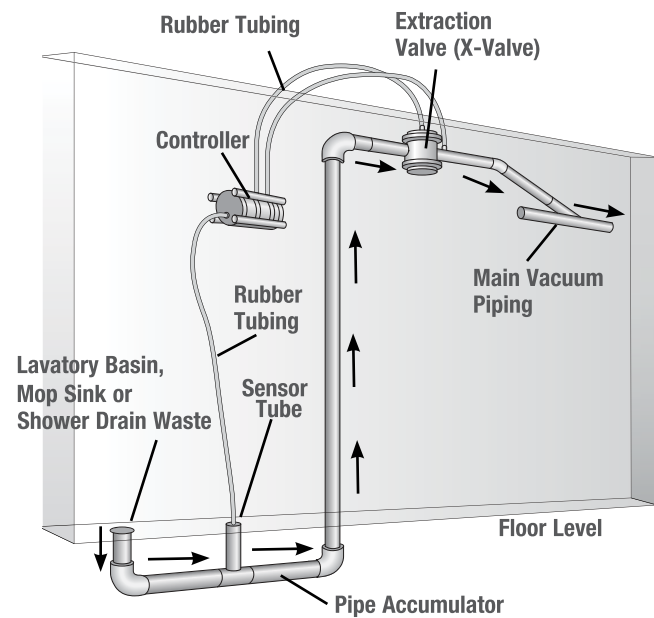
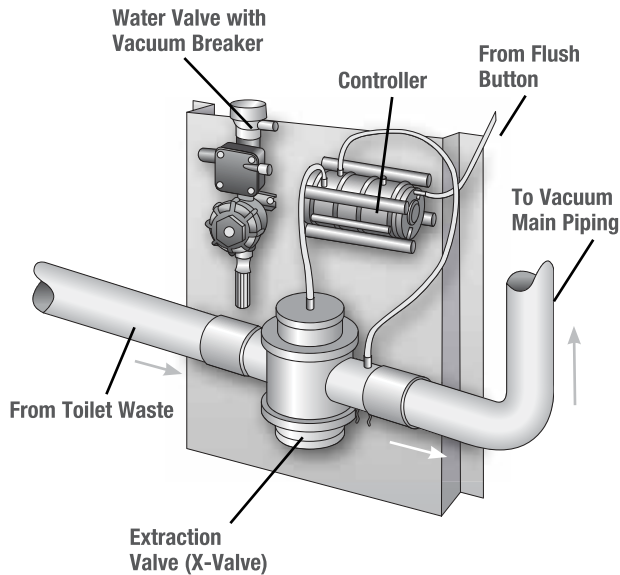

## Grey Water Drainage

### There are three primary components in a vacuum plumbing system:

- Vacuum Interface Valves and Intermediate Waste Collection Points
- Conveyance System – The Vacuum Waste Piping Network
- Vacuum Generating, Waste Collection and Disposal Components

### Vacuum Interface Valves and Intermediate Waste Collection Points

The vacuum interface components allow waste to be introduced into the vacuum waste piping network and transported to the vacuum center. These components include a normally closed Extraction Valve, which separates the vacuum in the piping from atmospheric pressure surrounding the fixture, and a Controller, which operates the Extraction Valve.

The water closet Extraction Valve is connected to the waste outlet, separating the toilet from the piping network. When the flush valve is activated, the Controller opens the Extraction Valve, allowing atmospheric pressure at the toilet bowl to push waste to the waste outlet, through the Extraction Valve and into the waste piping. Because air is used to transport wastewater, no water is required to initiate the flush cycle. The Controller also activates the flush water valve for rinse and re-fill of the bowl. The opening and closing of the Extraction Valve is precisely controlled so that all waste is completely removed from the bowl.

Since only ½ gallon of water per flush is required, Acorn-Vac toilets provide a significant reduction in water use and sewage output. The reduced water requirement also allows water supply line sizing to be significantly smaller than that required for 1.28 or 1.6 gallon flush valves. In addition, conventional waste venting is not required.

In the case of urinals, flushing sinks and any other non-flushing fixture, the waste drainage process is similar, but typically includes the use of an intermediate waste collection point, or Accumulator. As waste drains from the fixture, it is temporarily collected at the Accumulator. As waste fills the Accumulator, a signal is detected by the Controller which opens the Extraction Valve. This causes air to enter the Accumulator, mixing with the waste and transporting the resultant emulsion into the piping network.

### Conveyance System – The Vacuum Waste Piping Network

The vacuum waste piping or conveyance system is a closed piping network that is typically maintained under a continuous vacuum pressure of 16” – 18” Hg. (54 – 60 kPa) and is generally fabricated out of standard pressure rated PVC, Copper, or other smooth bore, non-porous material. The piping network consists of “risers” or “droppers” which transport the collected waste vertically from the point of origin to horizontal mains and branches leading to the Vac Center. Much like conventional waste piping, the mains and branches are typically installed with a slope of 1/4” per foot toward the Vac Center allowing the movement of waste to be assisted by gravity. However, unlike conventional waste piping,



*Waste Piping Can Be Routed Over-head, Horizontally*

a continuous slope to the Vac Center does not need to be maintained. The vacuum waste piping network can be offset to recover grade, which allows the piping network to route horizontally over long distances in very shallow space. In addition, the vertical or horizontal piping can be easily offset to route around obstacles in its' pathway toward the Vac Center. This feature can provide a significant benefit to the designer and installer when mechanical space is limited or when a conventional waste piping network can't be readily accommodated or installed.

## Vacuum Generating, Waste Collection and Disposal Components – The Vacuum Center

Commonly referred to as the “Vac Center”, the vacuum generating station includes vacuum pumps to create a continuous vacuum pressure within the piping network,

and storage tanks that collect and discharge the waste into the facilities' sewer main. In the case of sanitary waste, the Vac Center waste storage tanks are directly connected to sanitary sewer waste lines. Vacuum systems which provide drainage for greasy waste from food storage, display, or food preparation utility sinks are designed to allow for drainage from Vac Center waste collection tanks into code compliant grease interceptors, while vacuum systems processing condensate and grey water typically drain to a sanitary sewer through a code compliant air gap.

The vacuum waste piping network is directly connected to the Vac Center waste storage tanks. Waste travels under vacuum pressure from the fixture, through the piping network and into the Vac Center waste storage tanks, where it is temporarily held before discharge to sanitary waste lines or treatment equipment. Operation of the vacuum pumps and waste collection tanks is fully automated by controls provided with the Vac Center. The size of the vacuum pumps and waste collection tanks are determined by the total and potential future waste loads. In all cases, the Vac Center waste collection tanks and vacuum pumps are always selected and designed to provide redundant capacity.

The Vac Center controls automate the operation of the vacuum pumps which run only on demand as required to restore vacuum pressure to the waste collection tanks and piping network. Optional features allow remote visibility of the system operating status as well as visibility and control of individual valve operation.

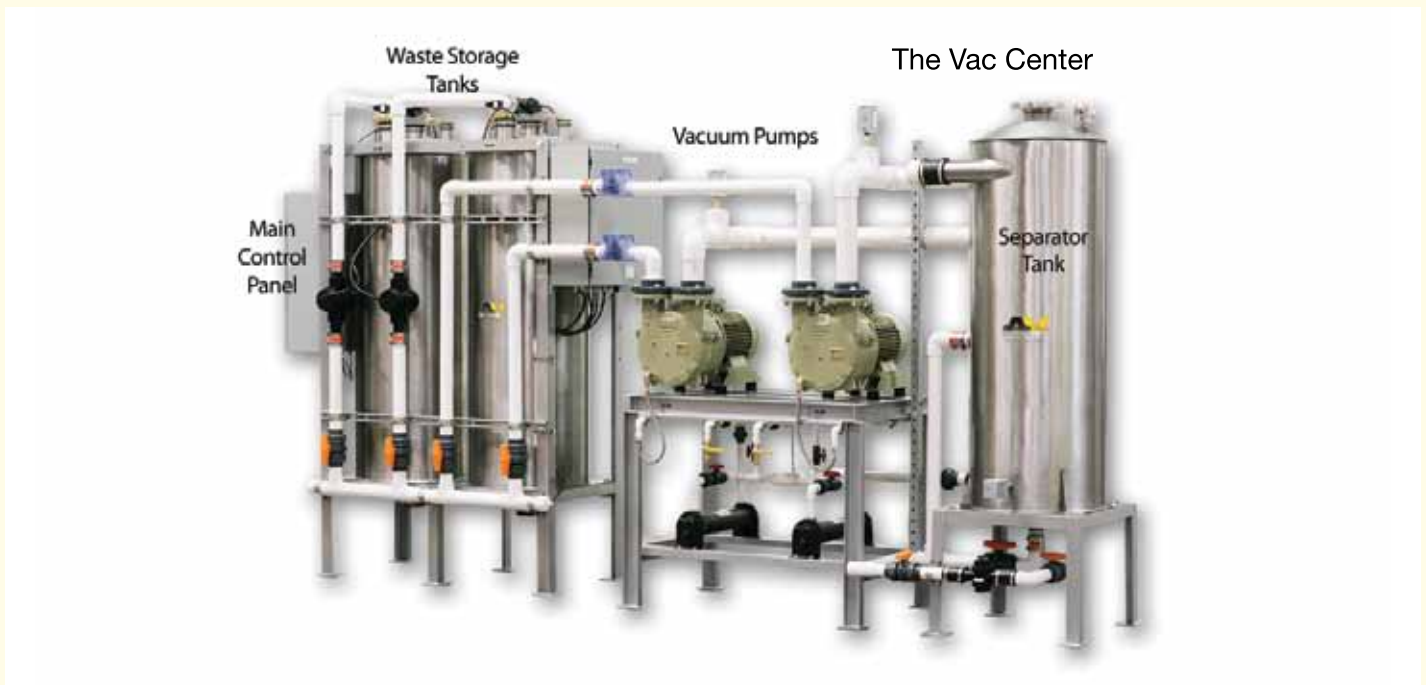

# AcornVac Products and Services

## We Can Assist You through the Entire Construction Process

Design • Construction • Operations • Maintenance

All AcornVac valve components are manufactured in the USA. The system is supported through our nationwide network of representatives. We offer direct assistance with system design, sizing, code approval, plan review, installation training, site visits, system start-up and commissioning.

### Our Championship Vacuum Plumbing Products Series

AcornVac is pleased to offer the Championship Vacuum Plumbing Series for smaller applications. The Championship Series' vacuum centers are tailored for projects with limited drainage requirements. They are designed to provide a fast and practical drainage solution for most retrofit, remodel and new construction environments.

The Championship Series eliminates the requirement for costly saw cutting and trenching for renovation projects requiring drainage where no immediate access to conventional underground sanitary waste lines exist, and allows projects to be completed in a fraction of the time.



What is best about the Championship Series is that it provides a framework for system sizing and application. Our systems are competitively priced to provide a cost saving alternative to conventional plumbing fixtures and equipment. These systems can be installed practically anywhere to supply drainage - even at remote locations in an existing building. They are great for tenant applications, big box retailers and distribution centers.

Championship Series Products	Descriptions						
	Collection Tanks	Vacuum Pumps				Capacity*	
System and Series Numbers	Qty	Volume (US Gal. Each)	Type	Qty	HP	Maximum "LPV"	Maximum Continuous Flow
<b>System 100</b> Series AV-20S-1.2-LR-BV	1	20	Liquid Ring	1	2	10	5 GPM
<b>System 150</b> Series AV-30S-2.2-LR-ST	1	30	Recirculating Liquid Ring	2	2	20	5 GPM
<b>System 200</b> Series AV-30S-2.2-LR	2	30	Recirculating Liquid Ring	2	2	35	15 GPM
<b>System 300</b> Series AV-30S-2.3-LR	2	30	Recirculating Liquid Ring	2	3	55	15 GPM
<b>System 500</b> Series AV-60S-2.5-LR-STK	2	60	Recirculating Liquid Ring	2	5	75	30 GPM
<b>System 1000</b> Series AV-60S-3.5-LR-3T-STK	3	60	Recirculating Liquid Ring	3	5	95	60 GPM

\*The maximum capacity of each system is based on maximum load point value or "LPV" (see chart above) and maximum continuous flow rate.





“AcornVac was very helpful throughout the design process, providing the necessary design and specification input. The installation of the system went very smoothly.”

Anthony Colacchia,  
M.E. Principal,  
Capital Engineering Consultants Inc.

## Our Services

### Custom Designed and Package System

If one of our Championship package systems is not right for your project, we can design, engineer and manufacture a vacuum system suitable for your application and design requirements. This is what we do; this is our expertise.

**These are our services with every order:**

### Planning

We offer comprehensive coordination with the engineer of record and owner during the design phase of the project to assist in system sizing, piping layout, and specification development. This includes a review of the scope of the project and drainage requirements, the creation of installation details and recommendations for piping layout.



### Construction and Commissioning

We help coordinate the commissioning of all areas of the system, along with diagnostic evaluation and recommendations for resolution of any areas of concern to ensure a functional and efficient installation.

### Installation

We offer comprehensive installation training for the installing contractor, covering system dynamics and proper installation requirements, supplemented by periodic inspection of the installation with detailed reporting regarding completion and correction of any installation deficiencies.

### Training, Support and Follow-up

We offer on-site training for facility maintenance staff, including a complete overview of the dynamics of the vacuum system, and comprehensive training in basic maintenance and trouble shooting.

### Service

We offer technical support through our Sales Engineering and Technical Services Departments. Our staff and representatives are available to facility maintenance personnel for telephone consultation at no additional cost on an ongoing basis.





## Championship Vacuum Plumbing Products Series

### Selecting the Right System

To select an appropriate Vacuum Center, you need to know the following:

- The type of equipment requiring drainage,
- The collective load point value of the fixtures and equipment requiring drainage

- Maximum anticipated continuous flow in gallons per minute, from all drainage combined.

If you need assistance, please contact AcornVac's Sales Engineering Department at 800-591-9920 or 909-902-1141, or by email at [info@acornvac.com](mailto:info@acornvac.com). You can find us on the web at [www.acornvac.com](http://www.acornvac.com).

Load Point Value	Project Data (Fill in the Blank)		
Fixture Type	LPV per Fixture	Quantity of Fixture Type	Total Item Value (Multiply Quantity By LPV Value)
Vacuum Toilet; .05 GPF	7		
Urinals	3		
Lavatory or Hand Wash Basin	1		
Floor Drains	5		
Mop or Utility Sink	5		
Multiple Bay Prep Sinks	10		
Misting Systems	1		
Refrigerated Case Equipment	.5		
AC Units	4		
Emergency Eye Wash	6		
<b>Total Project Load Points Value</b>			

### Sizing Your Champion

1. Calculate the total fixture load requirement by adding the total point value for all equipment requiring vacuum drainage.

2. Refer to the Maximum LPV in the table on page 14 to select the appropriate system.

3. Calculate the continuous flow rate for all fixtures combined. To do this, consider the normal use of the fixtures and equipment. Add the anticipated gallons per minute flow from all fixtures that might require drainage at the same time.



## An Example of Sizing Your Champion:

A stocking and distribution warehouse with men's and women's bathrooms

Load Point Value	Project Data (Fill in the Blank)		
Fixture Type	LPV per Fixture	Quantity of Fixture Type	Total Item Value (Multiply Quantity By LPV Value)
Vacuum Toilet; .05 GPF	7	3	21
Urinals	3	1	3
Lavatory or Hand Wash Basin	1	2	2
Floor Drains	5	2	10
Mop or Utility Sink	5	1	5
Multiple Bay Prep Sinks	10	0	0
Misting Systems	1	0	0
Refrigerated Case Equipment	.5	0	0
AC Units	4	0	0
Emergency Eye Wash	6	0	0
<b>Total Project Load Points Value</b>			<b>41</b>

In this example, the total Load Point Value is 41. This point value indicates System 300, from the Championship Series Products table – provided that the anticipated continuous in-flow rate from all fixtures

combined does not exceed 15-gallons per minute. If the anticipated continuous in-flow rate exceeds 15-gallons per minute, then select the system rated for 30-gallons per minute.

Championship Series Products	Descriptions						
	Collection Tanks	Vacuum Pumps				Capacity*	
System and Series Numbers	Qty	Volume (US Gal. Each)	Type	Qty	HP	Maximum "LPV"	Maximum Continuous Flow
<b>System 300</b> Series AV-30S-2.3-LR	2	30	Recirculating Liquid Ring	2	3	55	15 GPM

\*The maximum capacity of each system is based on maximum load point value or "LPV" (see chart above) and maximum continuous flow rate.

If the anticipated continuous in-flow rate exceeds the product offering within the Championship Series, please contact AcornVac's Sales Engineering Department at 800-591-9920 or 909-902-1141, or by email at [info@acornvac.com](mailto:info@acornvac.com). You can find this calculator and other product details on the web at [www.acornvac.com](http://www.acornvac.com).

# Championship Series

## System 100-Series AV-20S-1.2-LR-BV



### Product Description

Single frame factory assembled vacuum center consists of a 20 gallon T304 stainless steel waste collection tank, a 2 HP water sealed liquid ring vacuum pump, and a PLC driven automatic control panel.

### Features:

- Compact Design:  
25"[63.5cm] Long x 18"[46cm] Wide x 5'[1.5m] Tall
- System Weights:  
- Dry: 200lbs [90kg]  
- Wet: 375lbs [170kg]
- 20 gallon T304 stainless steel waste collection tank has 2" pipe size top waste inlet connection and 2" swing check waste outlet connection.
- 2 HP vacuum pump has 1/2" water supply inlet. Pump runs only on-demand. Water flows only when pump is on.
- Industrial grade panel has PLC driven automation control of vacuum pump and waste collection and discharge cycles. Panel includes a main disconnect, an alarm light and an HOA switch.
- Available 3-Phase 60 Hz Voltages:  
- 208 VAC – 5.8 FLA  
- 480 VAC – 3.4 FLA
- Dial face analog vacuum pressure gauge.

Descriptions						
Collection Tanks	Vacuum Pumps				Capacity*	
Qty	Volume (US Gal. Each)	Type	Qty	HP	Maximum "LPV"	Maximum Continuous Flow
1	20	Liquid Ring	1	2	10	5 GPM

\*The maximum capacity of each system is based on maximum load point value or "LPV" and maximum continuous flow rate.

# Championship Series

## System 150-Series AV-30S-2.2-LR-ST

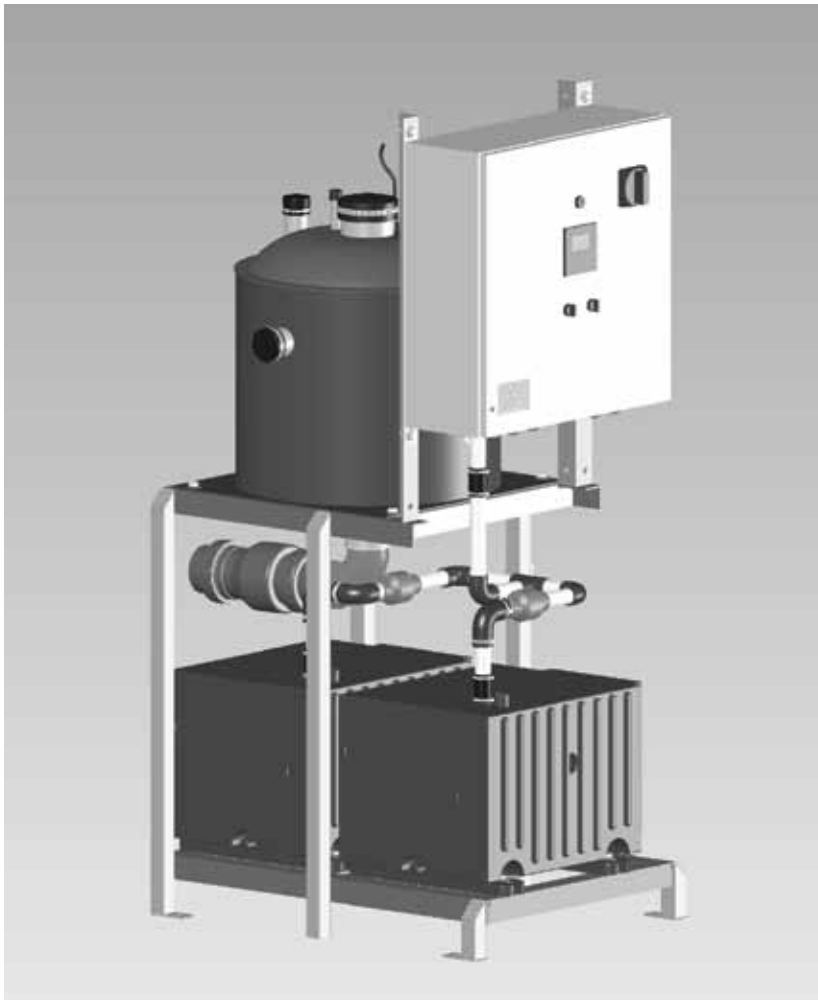

### Product Description

Single frame factory assembled vacuum center consists of a single 30 gallon T304 stainless steel waste collection tank, two 2 HP recirculating water sealed liquid ring vacuum pumps and a PLC driven automatic control panel.

### Features:

- Compact Design:  
41"[104cm] Long x 27-1/2"[70cm] Wide x 5'-10"[1.8m] Tall
- System Weights:  
- Dry: 650lbs [300kg]  
-Wet: 1050lbs [475kg]
- 30 gallon T304 stainless steel waste collection tank has 2" pipe size side waste inlet connection and 3" swing check waste outlet connection.
- Dual 2 HP vacuum pumps each have a 1/2" water supply inlet for pump water jacket fill float valve and a 1/2" overflow outlet. Pump water is fully recirculated through a cooling system requiring no continuous water supply.
- Industrial grade panel has PLC driven automation control of vacuum pumps and waste collection and discharge cycles. Panel includes a main disconnect, an alarm light, HOA switches, and an operator interface with digital display which shows vacuum system pressure and alarm status.
- Available 3-Phase 60 Hz Voltages:  
- 208 VAC – 11.3 FLA  
- 480 VAC – 6.5 FLA
- UPC and CUPC Approved.

Descriptions						
Collection Tanks		Vacuum Pumps			Capacity*	
Qty	Volume (US Gal. Each)	Type	Qty	HP	Maximum "LPV"	Maximum Continuous Flow
1	30	Recirculating Liquid Ring	2	2	20	5 GPM

\*The maximum capacity of each system is based on maximum load point value or "LPV" and maximum continuous flow rate.

# Championship Series

## System 200-Series AV-30S-2.2-LR

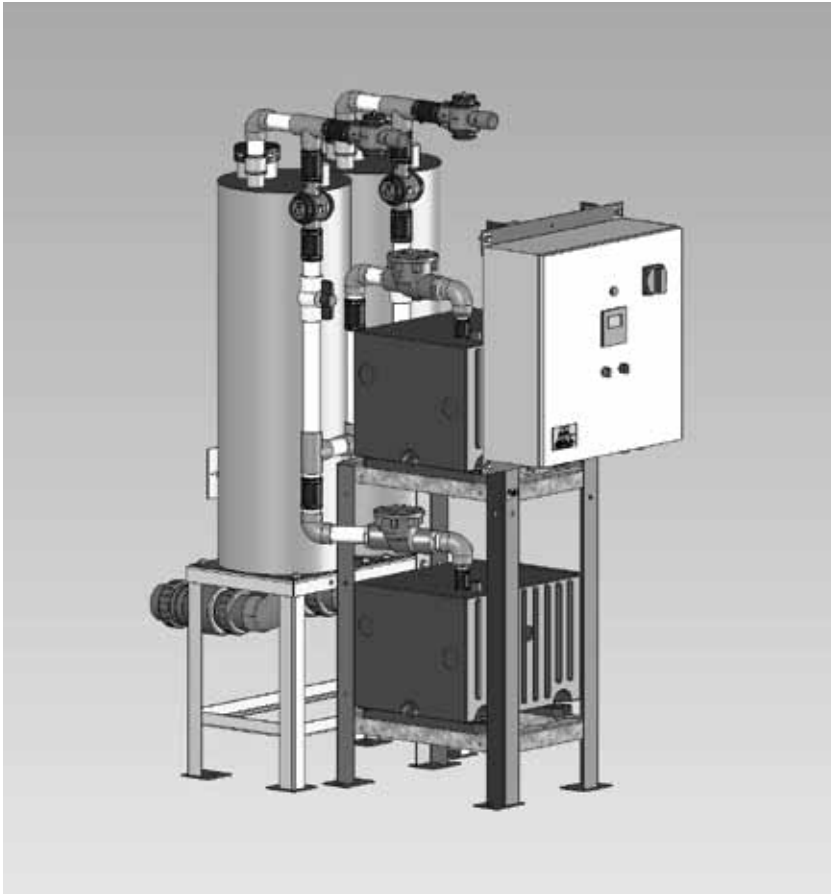

### Product Description

Fully redundant factory assembled vacuum center consists of one frame having two 30 gallon T304 stainless steel waste collection tanks bolted to second frame having two 2 HP recirculating water sealed liquid ring vacuum pumps and a PLC driven automatic control panel.

### Features:

- Fully Redundant & Compact Design:  
60-1/2"[154cm] Long x 32"[81cm] Wide x 6'-4"[1.9m] Tall
- System Weights:  
- Dry: 650lbs [300kg]  
- Wet: 1300lbs [600kg]
- Dual 30 gallon T304 stainless steel waste collection tanks each have a 2" pipe size top waste inlet connection and 3" swing check waste outlet connection.
- Dual 2 HP vacuum pumps each have a 1/2" water supply inlet for pump water jacket fill float valve and a 1/2" over flow outlet. Pump water is fully recirculated through a cooling system requiring no continuous water supply.
- Industrial grade panel has PLC driven automation control of vacuum pumps and waste collection and discharge cycles. Panel includes a main disconnect, an alarm light, HOA switches and an operator interface with digital display which shows vacuum system pressure and alarm status.
- Available 3-Phase 60 Hz Voltages:  
- 208 VAC – 11.3 FLA  
- 480 VAC – 6.5 FLA
- UPC and CUPC Approved.

Descriptions						
Collection Tanks	Vacuum Pumps				Capacity*	
Qty	Volume (US Gal. Each)	Type	Qty	HP	Maximum "LPV"	Maximum Continuous Flow
2	30	Recirculating Liquid Ring	2	2	35	15 GPM

\*The maximum capacity of each system is based on maximum load point value or "LPV" and maximum continuous flow rate.

# Championship Series

## System 300-Series AV-30S-2.3-LR

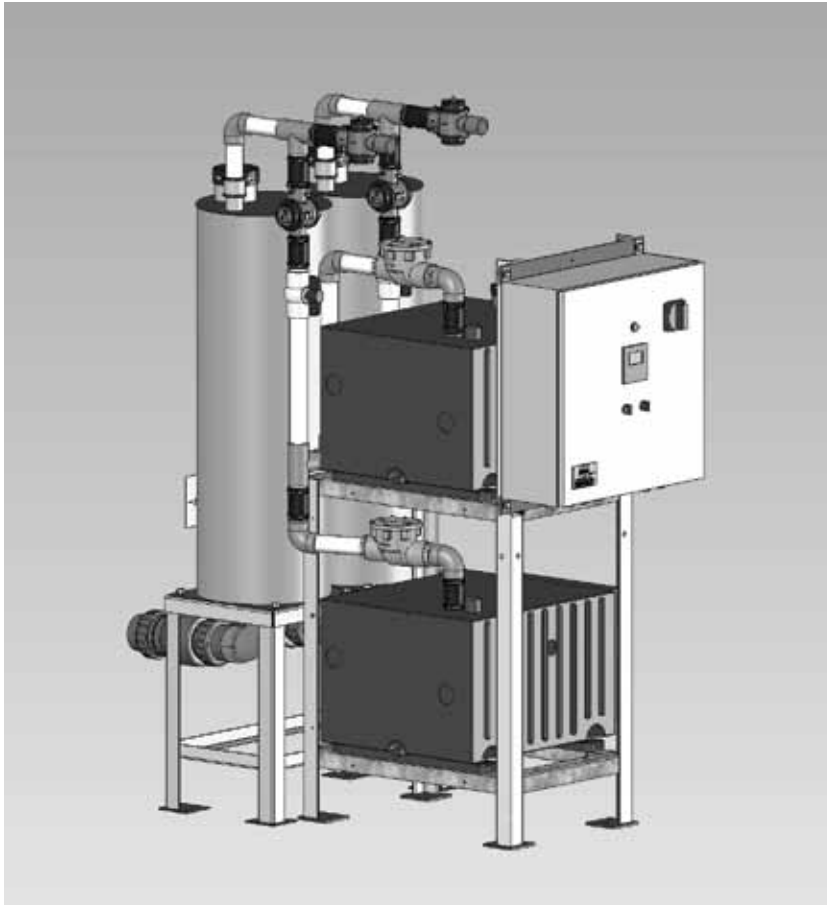

### Product Description

Fully redundant factory assembled vacuum center consists of one frame having two 30 gallon T304 stainless steel waste collection tanks bolted to second frame having two 3 HP recirculating water sealed liquid ring vacuum pumps and a PLC driven automatic control panel.

### Features:

- Fully Redundant & Compact Design:  
65-1/2"[165cm] Long x 33"[84cm] Wide x 6'-8"[2m] Tall
- System Weights:  
- Dry: 750lbs [350kg]  
- Wet: 1450lbs [650kg]
- Dual 30 gallon T304 stainless steel waste collection tanks each have a 2" pipe size top waste inlet connection and 3" swing check waste outlet connection.
- Dual 3 HP vacuum pumps each have a 1/2" water supply inlet for pump water jacket fill float valve and a 1/2" overflow outlet. Pump water is fully recirculated through a cooling system requiring no continuous water supply.
- Industrial grade panel has PLC driven automation control of vacuum pumps and waste collection and discharge cycles. Panel includes a main disconnect, an alarm light, HOA switches and an operator interface with digital display which shows vacuum system pressure and alarm status.
- Available 3-Phase 60 Hz Voltages:  
- 208 VAC – 20.3 FLA  
- 480 VAC – 11.7 FLA
- UPC and CUPC Approved.

Descriptions						
Collection Tanks		Vacuum Pumps			Capacity*	
Qty	Volume (US Gal. Each)	Type	Qty	HP	Max. "LPV"	Maximum Continuous Flow
2	30	Recirculating Liquid Ring	2	3	55	15 GPM

\*The maximum capacity of each system is based on maximum load point value or "LPV" and maximum continuous flow rate.

# Championship Series

## System 500-Series AV-60S-2.5-LR-STK

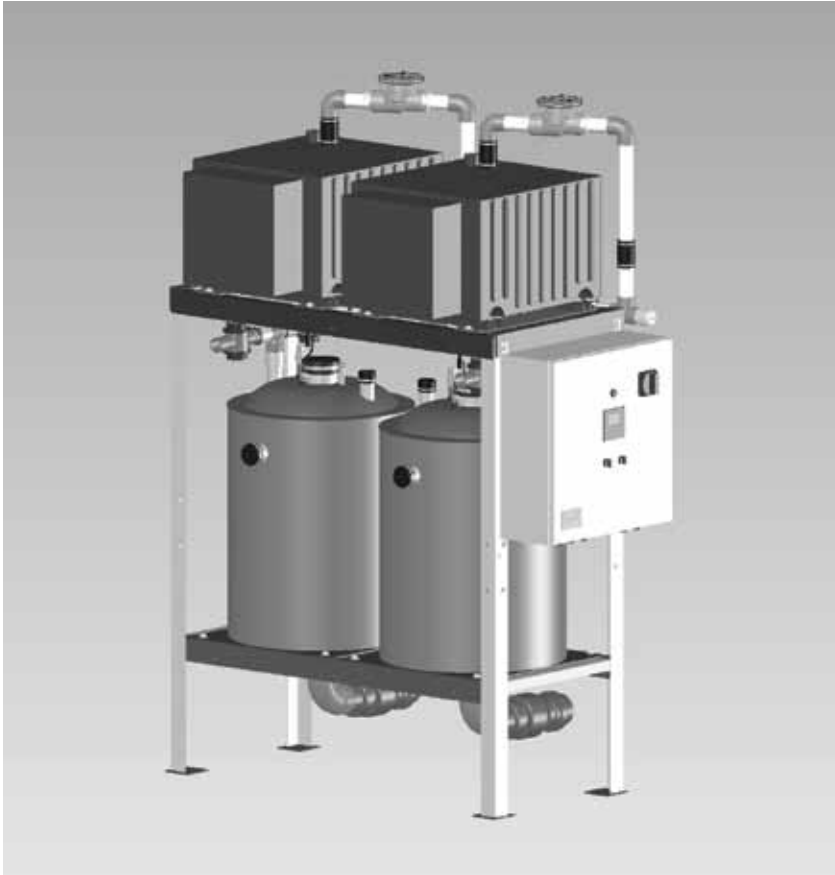

### Product Description

Fully redundant single frame factory assembled vacuum center consists of two 60 gallon T304 stainless steel waste collection tank, two 5 HP recirculating water sealed liquid ring vacuum pumps and a PLC driven automatic control panel.

### Features:

- Fully Redundant Design:  
65-1/2"[165cm] Long x 36"[91.5cm] Wide x 7'-6"[2.3m] Tall
- System Weights:  
- Dry: 950lbs [450kg]  
- Wet: 2350lbs [1050kg]
- Dual 60 gallon T304 stainless steel waste collection tanks each have a 2" pipe size side waste inlet connection and 3" swing check waste outlet connection.
- Dual 5 HP vacuum pumps each have a 1/2" water supply inlet for pump water jacket fill float valve and a 1/2" overflow outlet. Pump water is fully recirculated through a cooling system requiring no continuous water supply.
- Industrial grade panel has PLC driven automation control of vacuum pumps and waste collection and discharge cycles. Panel includes a main disconnect, an alarm light, HOA switches and an operator interface with digital display which shows vacuum system pressure and alarm status.
- Available 3-Phase 60 Hz Voltages:  
- 208 VAC – 34.5 FLA  
- 480 VAC – 19.9 FLA
- UPC and CUPC Approved.

Descriptions						
Collection Tanks	Vacuum Pumps				Capacity*	
Qty	Volume (US Gal. Each)	Type	Qty	HP	Max. "LPV"	Maximum Continuous Flow
2	60	Recirculating Liquid Ring	2	5	75	30 GPM

\*The maximum capacity of each system is based on maximum load point value or "LPV" and maximum continuous flow rate.



# Championship Series

## System 1000-Series AV-60S-3.5-LR-3T-STK



### Product Description

High Capacity fully redundant single frame factory assembled vacuum center consists of three 60 gallon T304 stainless steel waste collection tank, three 5 HP recirculating water sealed liquid ring vacuum pumps and a PLC driven automatic control panel.

### Features:

- High Capacity Fully Redundant Design: 90”[230cm] Long x 36”[91.5cm] Wide x 7’-6”[2.3m] Tall
- System Weights:
  - Dry: 1450lbs [650kg]
  - Wet: 3350lbs [1500kg]
- Triple 60 gallon T304 stainless steel waste collection tanks each have a 2” pipe size side waste inlet connection and 3” swing check waste outlet connection.
- Triple 5 HP vacuum pumps each have a 1/2” water supply inlet for pump water jacket fill float valve and a 1/2” overflow outlet. Pump water is fully recirculated through a cooling system requiring no continuous water supply.
- Industrial grade panel has PLC driven automation control of vacuum pumps and waste collection and discharge cycles. Panel includes a main disconnect, an alarm light, HOA switches and an operator interface with digital display which shows vacuum system pressure and alarm status.
- Available 3-Phase 60 Hz Voltages:
  - 208 VAC – 51.6 FLA
  - 480 VAC – 29.8 FLA
- UPC and CUPC Approved.

Descriptions						
Collection Tanks	Vacuum Pumps				Capacity*	
Qty	Volume (US Gal. Each)	Type	Qty	HP	Max. “LPV”	Maximum Continuous Flow
3	60	Recirculating Liquid Ring	3	5	95	60 GPM

\*The maximum capacity of each system is based on maximum load point value or “LPV” and maximum continuous flow rate.

# Three Levels of Vacuum Valve Control and Activation to Enhance Water Management

Pneumatic Control • Master-trol® • Zone Control

## AcornVac Pneumatic Manual Valve Control System

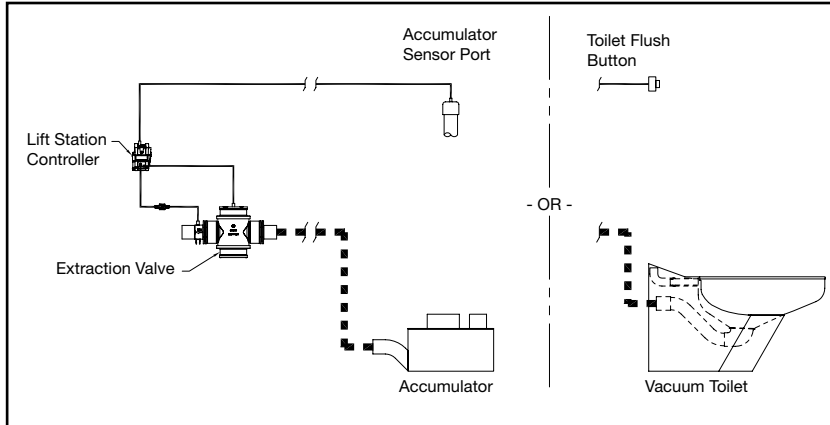

### Features:

- Low cost
- Vacuum powered – no electrical service required
- Pneumatic Controller includes manual activation button and adjustable valve control timing.

ADVANTAGES	DISADVANTAGES
No Electrical Power Required	No Visibility
Lowest Initial Cost	Limited Adjustability
	No Extra Functionality or Control

### Product Description

The AcornVac pneumatic control system is a low cost alternative to vacuum valve operation and control. The system includes pneumatic controllers which are used to operate the waste extraction valve. The valve controller is non-networked and is powered by vacuum pressure from the system, and thus requires no electrical service.

### How it works:

When the flush pushbutton on a toilet is pressed or when a change in pressure occurs at the accumulator, a pneumatic signal is received at the Controller. When this signal is received, the Controller uses vacuum from the system to open the waste extraction valve for a pre-set period of time sufficient to remove the waste from the accumulator or the toilet. Once the cycle is complete, the waste extraction valve closes. The Pneumatic Controller includes a timing mechanism that can be field adjusted.

# AcornVac Master-Trol® Electronic Valve Control System



## Features:

- Provides additional security and control for prison projects - can be used to prevent floods or abuse of water and waste valves.
- Easy installation
- Assists in regulating water use in large facilities and contributes to overall reduction in water consumption.
- Complete control and visibility of up to 3,072 valves

## Product Description

Master-trol is an electronic valve management system that allows both control and monitoring of water supply and vacuum waste valve activity through a dedicated server and software. All valves are controlled via a 12-port valve controller. The Master-trol server can also be tied to a local area network which allows for remote monitoring and control of valve activity.

As an example, Master-trol allows programmed valve operation limiting the number of flush valve activations within a given period of time and as well as limiting when and for how long a water faucet or shower is to remain active.

ADVANTAGES	DISADVANTAGES
Inexpensive Electronic Valve Control	More Expensive Than Pneumatic Valve Control
Precise, Repeatable Valve Operation	Limited Networking Capability
Fail Safe Mode	Limited Programmable Features

## How it works:

When the pushbutton on the fixtures is pressed, a signal is sent to the Controller, where a microprocessor identifies the valve and scans for pre-programmed options such as lockout settings, and timing restrictions. The controller returns an activation signal to the branch box signaling the solenoid operations valve, allowing valve operation.

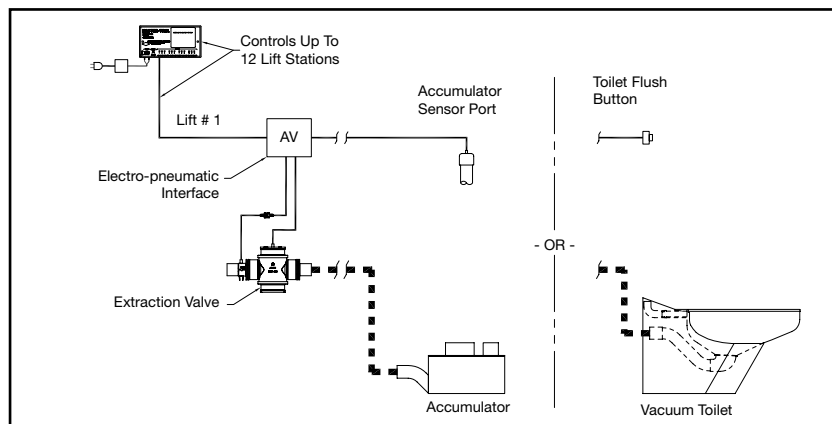

“Versa-Link” is the communications network that allows for monitoring and adjustment of up to 3,072 valves from a single computer. The Versa-link network, can accommodate up to 8 independent links, each of which can accommodate up to 32 controllers. Each controller provides monitoring of up to 12 individual valves – examples include hot water, cold water, flush valve and waste extraction valve.

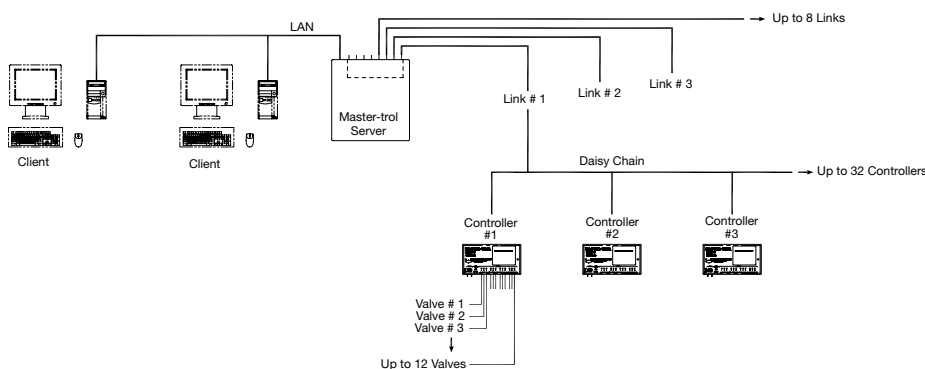

# AcornVac Zone Control System

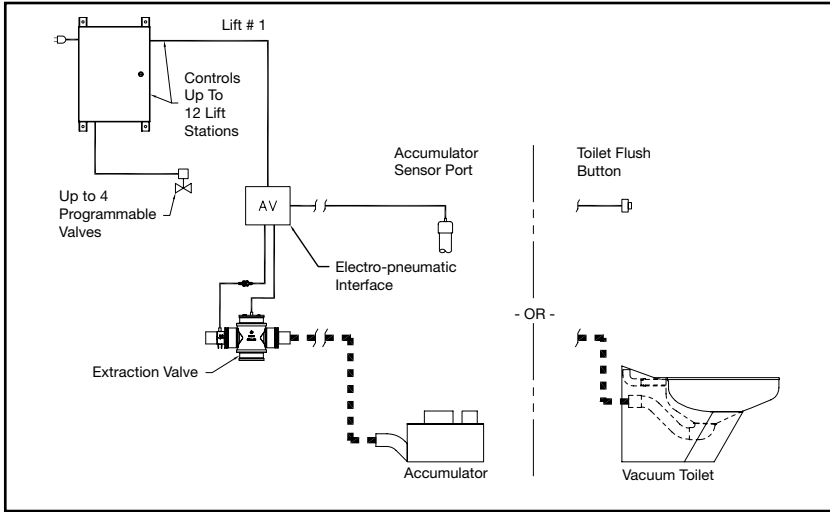

## Product Description

AcornVac Zone Control is a fully networked electronic valve control system that allows complete visibility and control of individually addressed vacuum waste extraction valves and ancillary or special purpose valves used for water supply shut off, flush, rinse or temperature control. Control and communication with individual valves is facilitated through system ZCP, which provide 24VDC power and control function for valves servicing up to 12 individual vacuum lifts. The entire system is designed to accommodate a maximum of 23 Zone Control Panels, or 276 individually addressed vacuum valves and 92 ancillary valves.

## Features:

- Individual electronic controller does not require dedicated power source or battery; power for valve control is provided by the Zone Control Panel (ZCP).
- Valve open time is optimized to ensure maximum operational efficiency of the entire system or manual over-ride to a fixed duration
- Data recording is provided which captures all valve activity for future review and programmed operation adjustment
- Fail-safe logic, designed to monitor ongoing lift activity and automatically implement corrective measures in the event of irregular valve operation

The Zone Control System includes local area network communication with all valves which allows them to be remotely monitored and controlled in real time, either from the vacuum center, or remote locations and building monitoring systems or networks. The system includes “fail-safe” logic, which is designed to monitor ongoing vacuum valve activity and automatically implement corrective measures in the event of irregular valve operation to ensure continuous waste drainage.

ADVANTAGES	DISADVANTAGES
Precise, Repeatable Valve Option	More Expensive than Master-trol® Valve Control
Optimize Waste Extraction Valve Operation - Minimize Pump Runtime	
Expanded Fail Safe Operation	
High Speed Networking	
All Valves/Functions Visible and Adjustable at Vac Center	
Historical Data	
Web Access	
Auto Alarm Notification	

## How it works:

Each ZCP monitors a fixture for a signal which is created automatically, or by pressing a button. When that signal is received, the ZCP opens a normally closed extraction valve to remove the waste from the fixture and transport it to the vac center. The duration the extraction valve is open is precisely controlled and optimized to minimize operation of the vacuum pumps. Each ZCP also provides control activation for up to four programmable ancillary valves associated with the waste extraction valve and used to facilitate waste drainage. Examples include flush valves, rinse valves, temperature control and shut off valves.

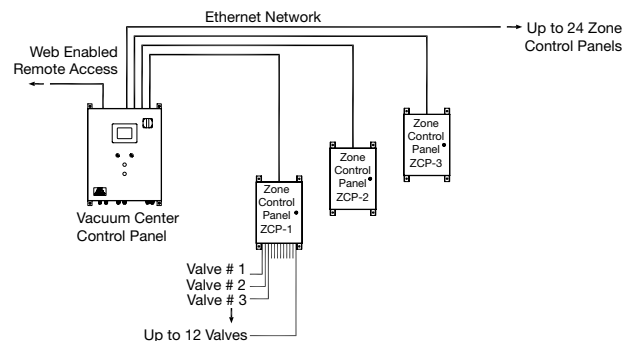

## Complementary Products



### Jay R. Smith Mfg. Co. Stainless Products – 9000 Series

The inherent durability of stainless steel makes it an ideal material for floor drains, floor sinks, floor cleanouts and trench drains, regardless of application. Stainless steel, with its intrinsically gratifying appearance, is perfect for facilities where hygienics, corrosion resistance and visibility are inherent.



### Jay R. Smith Mfg. Co. Grease Interceptors – 8000 Series

Jay R. Smith Mfg. Co. has conducted hundreds of tests, in the laboratory and in the field, in order to offer the most efficient Grease Interceptors with improved operational characteristics suitable for most applications. Smith's Grease Interceptors are

designed for practical applications. These interceptors bear the certification seal of the Plumbing and Drainage Institute (PDI). They can be installed either on-grade, semi-recessed or fully recessed in the floor.



### AcornVac Vacuum Waste System Toilets

The AcornVac Vacuum Toilet is made for ultra-efficient 0.5 gallon per flush water usage with the AcornVac Vacuum Waste System. The toilets are elongated bowl design with wall water supply and wall waste outlet connections. Models offered are economical vitreous china, durable stainless steel, or color enhanced Enviro-Glaze powder coat finished stainless steel. Vitreous china vacuum toilets are configured for off-floor installations. Stainless steel vacuum toilets are configured for off-floor or on-floor installations.



### Smith Drainage Systems - ENVIRO-FLO® Trench Drain Series

The ENVIRO-FLO® Trench Drain Series is the first of its kind in trench drain technology, encompassing all the compelling qualities you look for when deciding on a manufactured sloping trench drain system.

The lightweight, 100% polypropylene construction, along with the Enviro-Loc® mechanical interlocking joint, molded outlet connection for quicker and easier installations, and a complete selection of grate materials, make it contractor-friendly.

For more information on these or other Jay R. Smith Mfg. Co. products visit [www.jrsmith.com](http://www.jrsmith.com)

# Benefits for Institutional Construction

Prisons • Jails • Correctional Centers  
Designed to Fit Most Any Construction Challenge



- Direct connection of multiple toilets into the same waste stack is eliminated, thereby preventing inmates from passing contraband between cells.
- Vacuum toilets eliminate cell-to-cell communication that inmates often use to create “planned plumbing chaos” by organizing large “group flushes” that are typical for gravity drainage systems.
- The operational dynamics of a vacuum plumbing system result in fewer main line blockages, reducing maintenance cost and disruption. When toilet blockages do occur, they are easily located at the fixture, rather than within the waste line. This feature allows staff to easily identify inmates who routinely try to vandalize the plumbing system, promoting significantly improved security and control.
- Individual cells or groups of cells can be “turned off” prior to a security sweep to prevent contraband or other incriminating evidence from being flushed away.
- Vacuum flush toilets do not splash during the flush cycle, significantly reducing the spread of bacteria within the facility, promoting a healthier environment for staff and prison populations.

Installations:
<b>Western Virginia Regional Jail</b> Salem, VA
<b>Treatment Center at the Salinas Valley State Prison</b> Soledad, CA
<b>Poweshiek County Jail</b> Montezuma, IA
<b>Lotus Glenn Correctional Centre</b> Queensland, Australia

## Benefits for Food Service Industry

Supermarkets • Convenience Stores • Delicatessens  
Designed to Fit Most Any Construction Challenge



- Vacuum drainage systems eliminate the need for underground drainage piping in the sales area.
- Vacuum drainage systems allow existing buildings with limited drainage to be developed for supermarket use when traditional trenching and underground piping upgrades are cost prohibitive because of site or structural conditions such as post tension slab, bed rock, asbestos, high water tables, etc.
- Because trenching is eliminated, store remodel activities are less expensive, safer, more sanitary, and take less time.
- New construction projects can be completed faster, saving construction costs and allowing a facility to be brought online in a more timely fashion. Often, projects can be completed during inclement weather because the facility can be closed before the weather conditions prohibit construction.
- Vacuum drainage systems work in concert with the new “open” architectural store environment where electrical and refrigeration services are brought to display cases from overhead. Drainage can now follow these services, allowing for unprecedented flexibility in store layout.
- Vacuum drainage systems are completely adaptable to last minute merchandising changes.
- Vacuum drainage systems easily accommodate seasonal display requirements.
- Vacuum drainage systems create a cleaner environment and reduce health hazards associated with gravity drains.
- Vacuum drainage equipment can be capitalized and taken with the owner if the facilities are abandoned.

<b>Installations: Regionally and Nationally</b>
<b>Price Chopper/The Golub Corporation</b>
<b>Wegmans Food Markets</b>
<b>Target Corporation</b>
<b>Wal-Mart</b>
<b>Super Valu</b>
<b>Trader Joe's Company</b>
<b>Earth Fare, Inc.</b>
<b>Safeway, Inc.</b>

**Benefit for Health Care Facilities**  
**Laboratories • Clinics • Medical Centers**  
**Designed to Fit Most Any Construction Challenge**



- A vacuum toilet uses only ½ gallon of water per flush. This provides a significant savings in water supply and sewage disposal costs. These features may contribute to LEED and “green building” interests.
- Creates a cleaner environment and reduces the health hazards associated with renovation in an open facility. The operational dynamics of a vacuum plumbing system prevent waste ex-filtration, ensuring that contaminants stay within the waste piping network. The system dynamics also benefit the facility by reducing main line blockages, resulting in lower maintenance cost and operational disruption.
- The system contributes to a healthier, more sanitary environment, by eliminating the vaporization of water from the toilet bowl during a flush. This minimizes the spread of bacteria around the toilet fixture and within the facility.
- Vacuum provides a solution for routing waste piping through congested, space restricted areas. Because vacuum waste piping can be installed overhead and easily routed around existing mechanical, electrical or structural elements, it facilitates the relocation of plumbing fixtures and equipment without impacting floors below, and without concern for coordination with existing waste piping.

<b>Installations:</b>
<b>Albuquerque Regional Medical Center</b> Albuquerque, New Mexico
<b>Sutter Novato Medical Clinic</b> * Achieved LEED Certification * Novato CA
<b>Quintiles Blood Laboratory</b> Marietta GA
<b>Salt Lake City Olympic Medical Clinic</b> University of Utah Douglas Blvd.



# Grease Waste Transport System

## Designed to Fit Most Any Construction Challenge

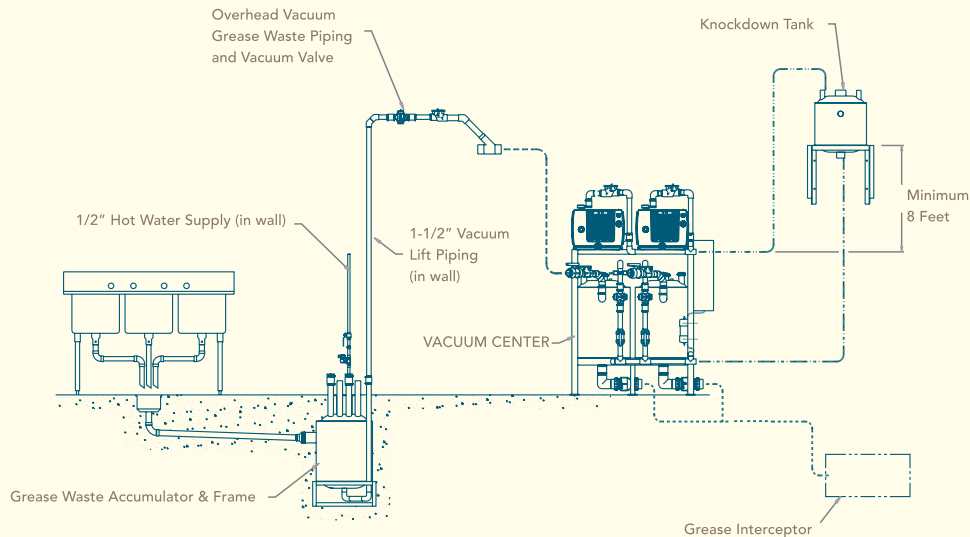

Transportation of grease waste effluent from source to interceptor has long been an issue for anyone that creates or works with conventional grease waste plumbing systems. AcornVac has developed an effective, reliable mode of transportation that conveniently integrates conventional fixtures or floor drains and routes grease waste through a vacuum waste piping network located above grade or slab for direct drainage to a more conveniently located grease interceptor. The system virtually eliminates problems with conventional grease

waste line clog and coagulation as well as placement, maintenance coordination and problems associated with local grease traps.

Vacuum Grease Transport Systems are simply a viable alternative to underground piping that use the combined energies of vacuum pressure and gravity for the transport of grease waste effluent through an above piping network that can be routed above grade.

### Vacuum drainage systems offer a number of benefits for a grease waste transport system:

- Vacuum transport systems eliminate the need for costly underground grease drainage piping in the sales area on renovation projects.
- Vacuum grease waste drainage replaces point-of-use grease interceptors from the food area with under-slab or above grade Vacuum Grease Accumulator(s). This eliminates the odor associated with regular maintenance and cleaning.
- The drainage piping network servicing a vacuum transport system can be installed vertically or horizontally, providing flexibility in layout and building design, thus the vacuum grease accumulator and grease interceptor can be placed anywhere in the building.
- The operational dynamics of a vacuum transport system result in significant reductions in grease waste build up in the waste piping network when compared to conventional gravity piping.
- Vacuum drainage systems work in concert with the new “open” architectural store environment where electrical and refrigeration services are brought to display cases from overhead. Grease waste piping within the store can now follow these services, allowing for unprecedented flexibility in store layout.
- Vacuum drainage systems are completely adaptable to last minute merchandising changes.
- New construction projects can be completed faster, providing a construction cost savings and allowing a facility to be brought online in a more timely fashion.

# FAQ

## Frequently Asked Questions

### **Q: What happens if the vacuum piping network develops a leak?**

A: Since the piping is maintained under a continuous vacuum, any leaks that might develop will draw air INTO the pipes, preventing waste infiltration.

The Acorn Vac Center is equipped with several alarm features that help alert maintenance personnel of any leaks that might develop in the vacuum piping network.

- For small leaks that lead to frequent pump cycling, an alarm will be generated indicating “Too Many Vacuum Pump Starts per Hour”.
- For moderate leaks that might keep a pump running continuously, an alarm will be generated indicating that the “Vacuum Pumps have run too long”.
- Should a major leak occur which causes the vacuum pressure to drop below minimum safety levels; the Vac Center will generate a “Low Vacuum Pressure” alarm.

Since the vacuum piping network exists in the overhead structure, finding and correcting vacuum system leaks is easily accomplished. By comparison, leaking pipes in an underground system may go undetected for years, possibly contaminating the surrounding area or water table.

### **Q: What about a catastrophic piping failure – such as a pipe breakage due to an earthquake?**

A: Unlike underground piping, a catastrophic piping failure, regardless of the cause, will be immediately identified and easily repaired.

### **Q: Since the system uses electrically operated vacuum pumps, what happens if power fails?**

A: Most facilities add the Vac Center to their standby power generating system. In fact, Acorn Vac offers a number of control features and hardware options to accommodate the unique needs of standby generator power sources. If the facility does not have a generator, or chooses not to add the Vac Center to the standby power source, the drainage system is simply not available until normal power is restored.

### **Q: Can the AcornVac system accept large water flows associated with multiple use scenarios, such as large office buildings or prisons?**

A: Yes. Proper engineering ensures that the system is sized for such events.

### **Q: What happens when unusually large debris gets into the system?**

A: Debris found to inhibit the performance of gravity drainage systems typically has little detrimental effect on the performance of the vacuum drainage system. In fact, items that would typically block a gravity drainage system will pass directly through the vacuum piping network to the Vac Center collection tanks due to the fact that they are assisted in their movement by atmospheric pressures entering the system in the course of normal operations. Vacuum drainage systems virtually eliminate clogged piping.

### **Q: Are spare parts available or should the facility carry spare parts themselves?**

A: All parts are supplied by AcornVac and are available for immediate shipment. However, a local factory certified maintenance contractor will stock a quantity of repair parts for emergency purposes.

### **Q: How fail-safe is the system? Is there any redundancy built-in?**

A: The AcornVac system is designed to provide complete redundancy on all primary Vac Center components. This includes dual collection tanks and multiple pumps to ensure that the system can continue to operate so long as electrical power is available.

When the Vac Center is operating on an emergency power generator, it is designed to switch the pump control strategy to a method that is most compatible with this power source. For those facilities with generators that have marginal capability for starting induction motor loads such as a vacuum pump, we offer electronic motor starters which minimize the inrush current of a pump as it is being brought on-line.

**Q: What are the recommended maintenance requirements?**

A: The primary service requirements would be at the Vac Center. The vacuum pumps are equipped with a small cartridge filter that we recommend be changed every twelve months. The pumps also have a cooling coil that should be cleaned once a year.

The AcornVac vacuum interface components have been tested to well over three million cycles without failure. These components have no regular required preventive maintenance. Should a problem occur with either a Controller or an Extraction Valve, the component is designed to be easily removed and replaced.

**Q: In a supermarket or hospital, is the system odor free?**

A: Yes. Any gasses or odors which might exist in the Vac Center collection tanks are discharged when the tank is drained, and any gasses or odors that might exist in the piping network are contained therein by the normally closed Extraction Valve and removed by the condensate extraction process.

**Q: Can the vacuum lift piping or risers be higher than 22'?**

A: Yes; however, the system must be engineered considering all load factors including anticipated activity and peak loads as well as diversity requirements. Call the AcornVac Engineering Department for design assistance.

**Q: Where are the controller valves, check valves, etc. made?**

A: All vacuum parts are made in the USA.

**Q: Does the vacuum system need vents (roof penetrations)?**

A: No, the vacuum system does not need vent stacks. Air removed from the piping network by the vacuum pumps becomes the vent for the system.



VACUUM PLUMBING SYSTEMS

**AcornVac, Inc.**

**Vacuum Plumbing Systems**

13818 Oaks Avenue, Chino, CA 91710

Tel. 800-591-9920 • Tel. 909-902-1141

Fax: 909-902-5041

Email: info@acornvac.com

www.acornvac.com

**ACORN FAMILY OF COMPANIES**



**ACORN AQUA**

Drinking Fountains

P.O. Box 3527 • City of Industry, CA 91744-0527 U.S.A.

Tel 800-591-9360 • Fax 626.855.4894

www.acornaqua.com



**ACORN-GENCON PLASTICS, LLC**

Injection Molded Products

13818 Oaks Avenue • Chino, CA 91710 U.S.A.

Tel 909-591-8461 • Fax 909-628-7465

www.acorn-gencon.com



**ACORN SAFETY**

Emergency Drench Systems

P.O. Box 3527 • City of Industry, CA 91744-0527 U.S.A.

Tel 800-591-9360 • Fax 626-937-1213

www.acornsafety.com



**ACORNVAC**

Vacuum Plumbing Systems

13818 Oaks Avenue • Chino, CA 91710 U.S.A.

Tel 800-591-9920 • 909 902-1141 • Fax 909-902-5041

www.acornvac.com



**CHRONOMITE LABORATORIES, INC.**

Tankless Electric Water Heaters

P.O. Box 3527 • City of Industry, CA 91744-0527 U.S.A.

Tel 800-447-4962 • Fax 626-937-4279

www.chronomite.com



**ELMDOR/STONEMAN MANUFACTURING**

Access Doors and Roof Flashing Assemblies

P.O. Box 3527 • City of Industry, CA 91744-0527 U.S.A.

Tel 800-591-9181 • 626-968-8699 • Fax 626-333-4109

www.emdorstoneman.com



**JAY R. SMITH MFG. CO.®**

Plumbing, Drainage and Rainwater Harvesting Products

P.O. Box 3237 • Montgomery, AL 36109-0237

Tel 800-467-6484 • 334-277-8520 • Fax 334-272-7396

www.jrsmith.com



**MURDOCK-SUPER SECUR**

Pre-engineered Modular Buildings,

Drinking Fountains, Water Hydrants

P.O. Box 3527 • City of Industry, CA 91744-0527 U.S.A.

Tel 800-591-9880 • 626-333-2543 • Fax 626-855-4860

www.murdock-supersecur.com



**NEO-METRO®**

Luxury Stainless Steel Plumbing Fixtures

P.O. Box 3527 • City of Industry, CA 91744-0527 U.S.A.

Tel 800-591-9050 • 626-855-4854 • Fax 626-937-4725

www.neo-metro.com



**POTTER ROEMER**

Fire Protection Equipment

P.O. Box 3527 • City of Industry, CA 91744-0527 U.S.A.

Tel 800-366-3473 • Fax 626-937-4777

www.potterroemer.com



**WHITEHALL MANUFACTURING**

Hospital and Therapy Products

P.O. Box 3527 • City of Industry, CA 91744-0527 U.S.A.

Tel 800-782-7706 • 626-968-6681 • Fax 626-855-4862

www.whitehallmfg.com



**ACORN ENGINEERING COMPANY**  
FAMILY OF COMPANIES

SPM 0503

L1001276

10/10